



IMPORTANT NOTICE TO THE EXHIBITORS OF:

LCD Exposition Services is pleased to have been selected as the Official Service Contractor. Our goal is to help make your showing a complete success. Please see the attached forms for equipment and services available to you.

Booth Package These items are provided at no additional cost to you:

Show Facts

Important Dates

Advance order discount deadline - **prepayment required**

Last day for shipments to arrive at Advance Warehouse without surcharges

Direct shipments may begin arriving at show site

Exhibitor Move-in

Event opens

Exhibitor Move-out

Policies

Recap and Payment Policy Form must accompany all orders!

Please fax or mail your order. Phone orders are not accepted.

Advance Order Pricing applies to orders received **prepaid** by

No credit will be applied to substitutions or changes to the booth package.

Cancellations after installation are invoiced at 50% of original price

Contacts

Show Management: (For questions regarding space assignments, show policies, or event schedules)

Exhibitor Services: (For questions regarding booth furnishings, additional equipment or Freight Services)

LCD Exposition Services

Phone: (509) 325-9656

Fax: (509) 325-9670



RECAP OF SERVICES ORDERED

ORDERS RECEIVED WITHOUT THIS FORM WILL NOT BE PROCESSED

SPECIAL BOOTH PACKAGE	\$ _____
CARPET	\$ _____
BOOTH FURNISHINGS - PAGE 1	\$ _____
BOOTH FURNISHINGS - PAGE 2	\$ _____
LABOR & BOOTH CLEANING	\$ _____
SIGNS, BANNERS & GRAPHICS	\$ _____
ELECTRICAL SERVICE	\$ _____
OTHER (total of any additional pages).....	\$ _____
SUB-TOTAL	\$ _____
SALES TAX	_____
FREIGHT HANDLING SERVICES (non taxable item)	_____
TOTAL	\$ _____

Please submit by fax to (509)325-9670 or by email to "orders@lcdexpo.com"

PAYMENT POLICY

**Advance order prices apply only to pre-orders received with full payment by
All orders received after the deadline, or without payment, will be charged at floor order prices**

- ❖ Orders placed at the show site must be guaranteed with a credit card.
- ❖ Cancellations & changes will be charged at 50% of the original price.
- ❖ Substitution of sponsor provided items is not permitted.
- ❖ Freight handling services only are exempt from sales tax.

ALL CHARGES MUST BE PAID PRIOR TO THE END OF THE EVENT

Please indicate your method of payment. All payments must be made in U.S funds.

CREDIT CARD

COMPANY CHECK

If you wish to authorize LCD Exposition Services to charge your credit card account for the amount of your advance order plus any additional amounts ordered by you or your representative at the show site, please complete the following section.

ACCT #	<input type="checkbox"/> VISA	<input type="checkbox"/> MC	<input type="checkbox"/> AMERICAN EXPRESS	EXPIRATION DATE	CVV CODE <small>VISA/MC three digits AMEX four digits</small>

Cardholder's Signature	Cardholder's Name (Please Print)

Company _____ **Booth** _____

Payment Address _____

City _____ **State** _____ **Zip** _____

Ordered by _____ **Phone** _____

Email (optional) _____



SPECIAL DISCOUNT BOOTH PACKAGE

LCD Exposition Services, your Official Trade Show Decorator, is pleased to offer special booth packages consisting of the most popularly ordered items. Please note substitutions can not be made to items in these packages.

PACKAGE A

This special booth package includes the following for the discounted price of \$189.00

One 9' GREY Carpet

One 6' draped table in your choice of colors (choose below)

Two side chairs

PACKAGE B

This special booth package includes the following for the discounted price of \$99.00

One 6' draped table in your choice of colors (choose below)

Two side chairs

Please indicate your color choice for table skirting here:

- Black Blue Burgundy Gold Red
- White Rust Light green Forest green

This pricing is only available if your order is received by

Total This Page: \$ _____

**PLEASE SEE COVER LETTER
AND PAYMENT POLICY FORMS
FOR ORDER INSTRUCTIONS**

EXHIBITOR _____

**PAYMENT POLICY / RECAP FORM
MUST ACCOMPANY THIS ORDER**

**ORDERED BY _____
(Please Print)**



CARPET ORDER FORM

- ❖ Rental includes installation, taping of aisle facing edges and removal at close of show.
- ❖ All carpeting is available in 9' widths only.
- ❖ Special carpet cutting and installation will be quoted on an individual basis.
- ❖ Plastic covering to protect your carpet during move in is available as an advance order only.
- ❖ Carpet padding is available in booth sizes only.

Quantity	Prepaid Advance Order	Floor Order
_____ 9' x 10' Nylon Carpet	\$95.00	\$125.00
_____ 9' x 20' Nylon Carpet	\$190.00	\$250.00
_____ 9' x 30' Nylon Carpet	\$285.00	\$375.00
_____ 9' x 40' Nylon Carpet	\$380.00	\$500.00
_____ Larger sizes (per sq. ft.)	\$1.05	\$1.40
_____ Custom Cut Carpet (per sq. ft.)	\$3.00	\$3.90

COLOR: Blue Burgundy Forest green Grey Red

**Carpet is available in 10' increments only at standard pricing.
For special size carpet please call for a quote!**

_____ 9' x 10' Carpet padding	\$47.50	\$62.50
_____ 9' x 20' Carpet padding	\$95.00	\$125.00
_____ 9' x 30' Carpet padding	\$142.50	\$187.50
_____ 9' x 40' Carpet padding	\$190.00	\$250.00
_____ Plastic Covering (per sq.ft., incl. installation & removal) ...	\$1.00	N/A
_____ 30 yd x 1" W carpet tape (meets facility requirements)	\$16.00	\$16.00

Total This Page: \$ _____

*PLEASE SEE COVER LETTER
AND PAYMENT POLICY FORMS
FOR ORDER INSTRUCTIONS*

EXHIBITOR _____

**PAYMENT POLICY / RECAP FORM
MUST ACCOMPANY THIS ORDER**

ORDERED BY _____
(Please Print)



ADDITIONAL BOOTH FURNISHINGS 1

SKIRTED WOOD TABLES & COUNTERS

Includes white vinyl top and choice of skirting

Quantity	Prepaid Advance Order	Floor Order
_____ 4' Wood table, 24" wide, 30" tall	\$67.00	\$87.00
_____ 6' Wood table, 24" wide, 30" tall	\$72.00	\$93.00
_____ 8' Wood table, 24" wide, 30" tall	\$78.00	\$101.00
_____ 4' Wood counter, 24" wide, 40" tall..	\$75.00	\$97.00
_____ 6' Wood counter, 24" wide, 40" tall..	\$82.00	\$106.00
_____ 8' Wood counter, 24" wide, 40" tall..	\$90.00	\$117.00

SKIRTING COLORS - please indicate choice:

- Black Blue Burgundy Gold Red
 White Rust Light green Forest green

_____ Skirting for 4th side, 30" tall *	\$33.00	\$43.00
_____ Skirting for 4th side, 40" tall *	\$37.00	\$48.00
_____ 30" White vinyl, per lineal foot	\$2.00	\$2.60

**available as addition to 6' or 8' skirted tables only
4' tables are already skirted on the 4th side*

UNSKIRTED WOOD TABLES & COUNTERS

_____ 4' Wood table, 24" wide, 30" tall ..	\$37.00	\$48.00
_____ 6' Wood table, 24" wide, 30" tall ..	\$39.00	\$51.00
_____ 8' Wood table, 24" wide, 30" tall ..	\$43.00	\$56.00
_____ 4' Wood counter, 24" wide, 40" tall..	\$42.00	\$54.00
_____ 6' Wood counter, 24" wide, 40" tall..	\$46.00	\$59.00
_____ 8' Wood counter, 24" wide, 40" tall..	\$49.00	\$63.00

SKIRTING FOR TABLES & COUNTERS

Quantity	Prepaid Advance Order	Floor Order
_____ 4' Skirting - 4 sides - 30" high	\$37.00	\$48.00
_____ 6' Skirting - 3 sides - 30" high	\$39.00	\$51.00
_____ 8' Skirting - 3 sides - 30" high	\$43.00	\$56.00
_____ 4' Skirting - 4 sides - 40" high	\$40.00	\$52.00
_____ 6' Skirting - 3 sides - 40" high	\$43.00	\$56.00
_____ 8' Skirting - 3 sides - 40" high	\$46.00	\$59.00

SKIRTING COLORS - please indicate choice:

- Black Blue Burgundy Gold Red
 White Rust Light green Forest green

DRAPED TABLE TOP RISERS

Covered with white vinyl

_____ 4' Table Riser, one step 10" wide	\$30.00	\$39.00
_____ 6' Table Riser, one step 10" wide	\$34.00	\$44.00
_____ 8' Table Riser, one step 10" wide	\$40.00	\$52.00
_____ 4' Table Riser, two step 10" wide ea	\$42.00	\$54.00
_____ 6' Table Riser, two step 10" wide ea	\$52.00	\$67.00
_____ 8' Table Riser, two step 10" wide ea	\$64.00	\$83.00

**WE ARE CONTIUALY UPDATING OUR EQUIPMENT.
IF YOU HAVE ANY QUESTIONS, OR CAN'T FIND AN
ITEM YOU WANT, PLEASE CALL OUR OFFICE AT
(509) 325-9656 OR EMAIL "ORDERS@LCDEXPO.COM"**

Total This Page: \$ _____

PLEASE SEE COVER LETTER
AND PAYMENT POLICY FORMS
FOR ORDER INSTRUCTIONS

EXHIBITOR _____

PAYMENT POLICY / RECAP FORM
MUST ACCOMPANY THIS ORDER

ORDERED BY _____
(Please Print)



ADDITIONAL FURNISHINGS 2

MISCELLANEOUS BOOTH FURNITURE

Quantity		Prepaid Advance Order	Floor Order
_____	Side chair	\$22.50	\$29.00
_____	Arm chair	\$26.50	\$34.00
_____	Bar stool with backrest	\$58.00	\$75.00
Pedestal tables below include black linen			
_____	30" round pedestal table, 15" tall ...	\$63.00	\$82.00
_____	30" round pedestal table, 30" tall ...	\$63.00	\$82.00
_____	30" round pedestal table, 40" tall ...	\$63.00	\$82.00
_____	Wastebasket	\$15.00	\$19.00
_____	Metal easel	\$25.00	\$32.00
_____	Literature rack	\$40.00	\$52.00
_____	Coat Tree	\$40.00	\$52.00
_____	Deluxe chrome rope stand	\$25.00	\$32.00
_____	Deluxe rope for above, per lineal foot	\$2.00	\$2.60
_____	Aluminum rope stand	\$10.00	\$13.00
_____	LED overhead floodlight	\$62.00	\$80.00

**Other lighting needs? Please call or email:
509-325-9656 or orders@lcdexpo.com**

SPECIAL BOOTH DRAPERY

_____	8' high drapery, per lineal foot	\$6.50	\$8.50
_____	3' high drapery, per lineal foot	\$4.50	\$5.75
_____	12' high drapery, per lineal foot	\$12.00	\$15.50
_____	Framework only - no drape, per ft.	\$3.75	\$3.75

Select height: 3'h 8'h 12'h

Black
 Blue
 Burgundy
 Gold
 Red
 White
 Rust
 Light green
 Forest green

FRAMED PERFORATED BOARD - 1/4" HOLES

Quantity		Prepaid Advance Order	Floor Order
_____	4'x8' Vertical single sided	\$95.00	\$123.00
_____	4'x8' Vertical double sided	\$110.00	\$143.00
_____	2'x8' Vertical single sided	\$75.00	\$97.50
_____	4'x8' Horizontal single sided	\$95.00	\$123.00
_____	4'x8' Horizontal double sided	\$110.00	\$143.00
Color: <input type="checkbox"/> White <input type="checkbox"/> Brown			
_____	4'x8' Poster Board - two sided ...	\$95.00	\$123.00
Poster Board only accepts pins			

PLANTS AND FLORAL SERVICES

Please call for quote

Flowering plants and balloon bouquets are **purchases**.
You may take them with you after the show.

All plants and balloons subject to a delivery charge.

**WE ARE CONTINUALLY UPDATING OUR EQUIPMENT.
IF YOU HAVE ANY QUESTIONS, OR CAN'T FIND AN
ITEM YOU WANT, PLEASE CALL OUR OFFICE AT
(509) 325-9656 OR EMAIL "ORDERS@LCDEXPO.COM"**

Total This Page: \$ _____

**PLEASE SEE COVER LETTER
AND PAYMENT POLICY FORMS
FOR ORDER INSTRUCTIONS**

EXHIBITOR _____

**PAYMENT POLICY / RECAP FORM
MUST ACCOMPANY THIS ORDER**

ORDERED BY _____
(Please Print)



LABOR & BOOTH CLEANING

EXHIBIT INSTALLATION SERVICE

We will require _____ men and approximately _____ hours to install our exhibit.

- Please supervise exhibit installation. *
- Our representative will be present to supervise.

Schedule labor for: Date _____ Time _____

Supervisor _____

EXHIBIT DISMANTLING SERVICE

We will require _____ men and approximately _____ hours to dismantle our exhibit.

- Please supervise exhibit dismantling.*
- Our representative will be present to supervise.

*** If your representative will not be present to supervise a surcharge of 25% of total labor cost will apply.**

BOOTH CLEANING SERVICE

Includes daily vacuuming of carpet and emptying of wastebaskets.

- Per sq. ft., ONCE before opening only
(100 sq. ft. minimum) @ 00.45/s.f. _____
- Per sq. ft., per day of show run
(100 sq. ft. minimum) @ 00.40/s.f. _____
- Large Booths
500 s.f. & over, per day @ 00.30/s.f. _____

If you have special instructions please note them here. If you will not be supervising the labor please attach or send setup instructions.

LABOR RATES

Quantity		Per Hour Straight Time	Per Hour Over- time
_____	Man hours, one hour minimum	\$70.00	\$105.00
_____	Forklift & driver, 1/2 hour minimum	\$125.00	\$187.50

Please note: Straight time is from 8 AM to 5 PM weekdays. Overtime applies before 8 AM and after 5 PM weekdays and all day Saturday, Sunday and Holidays.

PAYMENT IN FULL MUST ACCOMPANY THIS ORDER!

Total This Page: \$ _____

**PLEASE SEE COVER LETTER
AND PAYMENT POLICY FORMS
FOR ORDER INSTRUCTIONS**

EXHIBITOR _____

**PAYMENT POLICY / RECAP FORM
MUST ACCOMPANY THIS ORDER**

ORDERED BY _____
(Please Print)



ELECTRICAL ORDER FORM

**All electrical outlets will be located in the center back of the booth.
Please check UL rating plate on equipment, and order outlets accordingly.**

DUPLEX ELECTRICAL OUTLET - 110 VOLT			
Quantity		Prepaid Advance Order	Floor Order
_____	500 Watt, or 5 amp	\$60.00	\$78.00
_____	1000 Watt, or 10 amp	\$75.00	\$97.50
_____	1500 Watt, or 15 amp	\$90.00	\$117.00
_____	2000 Watt, or 20 amp	\$105.00	\$136.50

Outlets requiring 24 hour service and / or a dedicated circuit will be charged an additional 50% of the listed price.

All 208v services 30 amps and under include a NEMA L21-30 receptacle. If you require a specific receptacle for your equipment, a labor and materials charge for installation will apply.

Charges listed are for providing access to your location at the event. Access may not be available in all facilities. If direct wiring is required please call. Electrician costs and permit fees are not included.

SINGLE ELECTRICAL OUTLETS 208 Volt / single phase			
_____	20 amps	\$120.00	\$156.00
_____	30 amps	\$140.00	\$182.00
_____	40 amps	\$170.00	\$220.00
_____	50 amps	\$195.00	\$255.00

SINGLE ELECTRICAL OUTLETS 208 Volt / three phase			
Not available in all facilities ... please call to confirm.			
_____	20 amps	\$125.00	\$163.00
_____	30 amps	\$152.00	\$198.00
_____	40 amps	\$178.00	\$232.00
_____	50 amps	\$204.00	\$265.00

For 208v services requiring a special receptacle please provide a sketch or NEMA code here



EXAMPLE

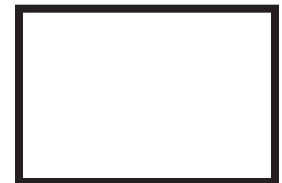

EXTENSION CORDS / POWER STRIPS			
_____	25' Heavy duty extension cord	\$17.50	\$23.00
_____	6 outlet power strip	\$17.50	\$23.00

PAYMENT IN FULL MUST ACCOMPANY THIS ORDER!

50% Additional charge for dedicated circuit(s) and / or uninterrupted service \$ _____

Total This Page: \$ _____

**PLEASE SEE COVER LETTER
AND PAYMENT POLICY FORMS
FOR ORDER INSTRUCTIONS**

EXHIBITOR _____

**PAYMENT POLICY / RECAP FORM
MUST ACCOMPANY THIS ORDER**

ORDERED BY _____
(Please Print)



SIGNS, BANNERS, & DIGITAL GRAPHICS

STANDARD BOOTH SIGNS & SHOWCARDS

Digitally printed signs on white 1.2 mil cardstock.
 Suitable for booth signs, smaller table top or easel signs.
 Not recommended for photo quality output.

Qty	Standard Sizes	Prepaid Advance Order	Floor Order
_____	7" x 11"	\$25.00	\$33.00
_____	7" x 40"	\$30.00	\$39.00
_____	11" x 40"	\$33.00	\$43.00
_____	11" x 14"	\$30.00	\$39.00
_____	14" x 22"	\$35.00	\$46.00
_____	18" x 22"	\$38.00	\$50.00
_____	Add easel back for tabletop signs	\$15.00	

custom sizes available, please call for quote

Orientation:  Horizontal  Vertical Use our best judgement

FOAMCORE BACKED SIGNS

Digitally printed signs mounted on white foamcore.
 Great for larger signs requiring a rigid backing.
 High quality output up to 42"x96".

Qty	Standard Sizes	Advance Order	Floor Order
_____	7" x 11"	\$35.00	\$45.00
_____	7" x 42"	\$40.00	\$52.00
_____	11" x 42"	\$45.00	\$58.00
_____	11" x 14"	\$40.00	\$52.00
_____	14" x 22"	\$45.00	\$58.00
_____	18" x 22"	\$50.00	\$65.00
_____	22" x 28"	\$60.00	\$78.00
_____	28" x 42"	\$90.00	\$117.00
_____	42" x 60"	\$180.00	\$230.00
_____	42" x 96"	\$220.00	\$280.00
_____	Add easel back - for up to 22" x 28"	\$15.00	

custom sizes available, please call for quote

Orientation:  Horizontal  Vertical Use our best judgement

VINYL BANNERS

Digitally printed on white 15ml vinyl banner stock.
 Only available as Advance Order.
 Please note graphic guidelines below.

Includes hanging tabs on corners and every two feet.

Requested size	Advance Order
24" material - 3' minimum length	\$75.00
_____ each additional foot x \$9.00	_____
Total	_____
<hr/>	
36" material - 2' minimum length	\$67.50
_____ each additional foot x \$11.00	_____
Total	_____
<hr/>	
42" material - 3' minimum length	\$85.00
_____ each additional foot x \$13.00	_____
Total	_____

Orientation:  Horizontal  Vertical Use our best judgement

GRAPHICS GUIDELINES

Please attach instructions and sign copy including color of text.
 Prices include up to 25 words - more intensive copy will be quoted separately.

For best results send vector graphics in .eps or Illustrator .ai format. Include all fonts or convert them to outlines. Include any linked files or images.

For raster images .jpg, .tif, or photoshop .psd are acceptable at actual size at 100 dpi.

Please include a hard copy or .pdf file of your artwork.

Graphic Design services are available at the rate of \$65.00 per hour.

TOTAL THIS PAGE \$ _____

**PLEASE SEE COVER LETTER
 AND PAYMENT POLICY FORMS
 FOR ORDER INSTRUCTIONS**

EXHIBITOR _____

**PAYMENT POLICY / RECAP FORM
 MUST ACCOMPANY THIS ORDER**

ORDERED BY _____
 (Please Print)

PHONE OR
 EMAIL _____

DISPLAY SYSTEM RENTAL FORM

10' FULL FLOOR DISPLAY UNIT

CONVERTS TO TABLE TOP

by INTEX - Gatefold design - top and bottom units stack
 Reversible - either black or silver grey fabric - Velcro attachable
 5 panels top and bottom 22.5" x 45.5" - 112.5" w x 91" h overall

Available configurations:	Advance Order	Floor Order
___ (a) Full unit (includes 2 lights)	\$450.00	\$575.00
___ (c) 5 panel table top (no header)	\$260.00	\$338.00
___ Lights for table top	\$33.00	\$40.00
___ Labor to install (optional)	\$70.00	\$70.00
___ Labor to dismantle/repack (optional)	\$70.00	\$70.00

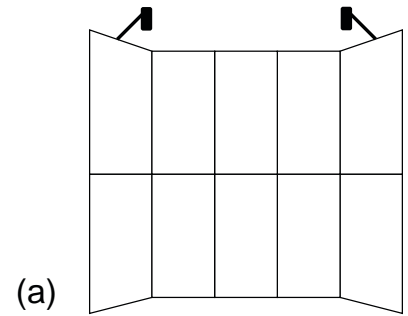

10' FULL FLOOR DISPLAY UNIT

CONVERTS TO TABLE TOP

by Featherlite - Gatefold design - top and bottom units stack
 Reversible - either coal or silver fabric - Velcro attachable
 5 panels middle 8'h x 22"w
 5 panels top and bottom 22" x 44" - 110" w x 96" h overall w/mid section
 Header is 8" h x 44" w

Available configurations:	Advance Order	Floor Order
___ (b) Full unit (includes 2 lights)	\$450.00	\$575.00
___ (c) 5 panel table top with header	\$260.00	\$338.00
___ Lights for table top	\$33.00	\$40.00
___ Labor to install (optional)	\$70.00	\$70.00
___ Labor to dismantle/repack (optional)	\$70.00	\$70.00

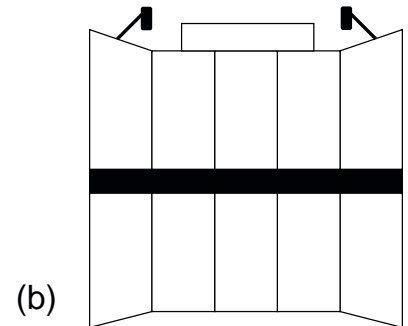

6' TABLE TOP DISPLAY UNIT

by Featherlite - Gatefold design
 Reversible - either blue or silver fabric - Velcro attachable
 4 panels 22" x 44" - 88" w x 44" h overall
 Header is 11" h x 44" w

___ (d) 4 panel table top (lights N/A)	\$220.00	\$285.00
___ Labor to install (optional)	\$70.00	\$70.00
___ Labor to dismantle/repack (optional)	\$70.00	\$70.00

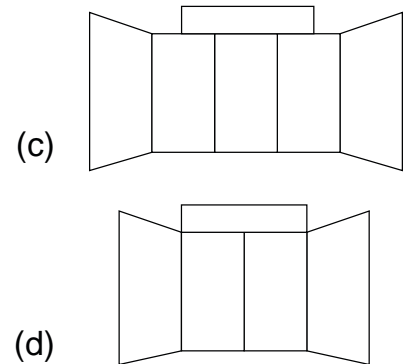

10' CURVED POP-UP DISPLAY

by Classic Displays
 Black or Navy Blue fabric - Velcro attachable
 Overall dimensions 90" high x 108" wide

___ (e) Pop-up display <input type="checkbox"/> Black <input type="checkbox"/> Navy	\$450.00	\$575.00
___ Labor to install (optional)	\$70.00	\$70.00
___ Labor to dismantle/repack (optional)	\$70.00	\$70.00

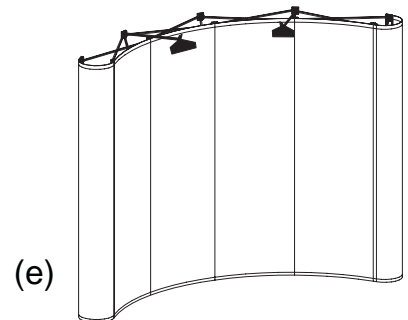

*PLEASE SEE COVER LETTER
 AND PAYMENT POLICY FORMS
 FOR ORDER INSTRUCTIONS*

**PAYMENT POLICY / RECAP FORM
 MUST ACCOMPANY THIS ORDER**

Quantities limited - please order early

Total This Page: \$ _____

EXHIBITOR _____

ORDERED BY _____

(Please Print)



SHIPPING AND DRAYAGE INFORMATION

THE EXHIBIT FACILITY **WILL NOT** ACCEPT ADVANCE SHIPMENTS

GENERAL INFORMATION

- ❖ Direct shipments to the exhibit facility will only be accepted during move in hours, and are subject to handling charges unless your representative is available to sign for delivery
- ❖ If you wish LCD Exposition Services to assist you with your freight handling needs, your shipments should be addressed as follows:

TO: (Your company name)
FOR: **Booth #**
C/O: LCD Exposition Services
220 E Augusta Ave
Spokane, WA 99207

- ❖ Please mark your shipment with your booth number if known.
- ❖ **All shipments must be prepaid. Collect shipments will be refused!**
- ❖ Warehouse shipments received after _____ will be subject to 25% surcharge.
- ❖ International shipments must include the required documents for return shipping. Your customs broker can supply these documents. Lack of documents will delay return shipping.
- ❖ Copies of all bills of lading should be sent to LCD Exposition Services at time of shipment.
- ❖ *Freight handling charges are exempt from sales tax.*
- ❖ Outbound UPS or Fedex parcel shipments will be charged an additional handling fee of \$6.00 per piece, with a minimum charge of \$18.00 per shipment.
- ❖ Freight handling will be charged in 100# increments based on actual weight.
- ❖ All freight handling services must be guaranteed with a credit card
- ❖ **Attention Fedex Ground Customers:** *Fedex Ground does not allow collect or third party billing. We cannot process outbound Fedex Ground Shipments unless you provide your own prepaid return shipment labels. This restriction does not apply to Fedex Express (air) shipments.*

LIABILITY LIMITATIONS:

LILAC CITY DECORATORS, INC. as LCD Exposition Services (LCD) shall not be responsible for damage to uncrated materials, to materials improperly packed, for concealed damage, or for loss or theft of materials after delivery to booth or before materials have been picked up for loading from the exhibit site. LCD will not be responsible for shipments left in booth by exhibitor, and all shipments will be counted and shipped as found by LCD. LCD WILL ROUTE ALL FREIGHT UNLESS ADVANCE ARRANGEMENTS HAVE BEEN MADE. Exhibits and materials for which arrangements have not been made with LCD, or which have not been removed from the exhibit area on move out day will be routed to our warehouse, at exhibitor expense, to await disposition. LCD reserves the right to route exhibit materials via an alternate carrier in the event the designated carrier fails to pick up the shipment within a reasonable time after the close of the show

The liability of LILAC CITY DECORATORS, INC. is limited to \$00.65 per pound per article, with a maximum of \$65.00 per item. Values exceeding this limitation should be insured by the exhibitor.



FREIGHT SERVICE ORDER FORM

MATERIAL HANDLING RATE SCHEDULE *All Charges Based on Actual Weight in 100# Increments*
COLLECT SHIPMENTS WILL BE REFUSED!

All Receiving Services include the following: Receipt of shipment from carriers, delivery to booth; storage & return of empty containers, return of shipment to your carrier at the close of the event.

Warehouse Shipments received after *subject to 25% additional handling fee.*

RECEIVING AT ADVANCE WAREHOUSE: Includes advance storage up to 30 days.

\$65.00 per 100# with a 200# minimum

RECEIVING AT EXHIBIT HALL - EXHIBITOR MOVE IN HOURS ONLY:

\$65.00 per 100# with a 200# minimum

SMALL PARCEL RATE: Cartons weighing under 30# each. Maximum of three cartons at this rate.

\$35.00 per carton with a two carton minimum

OUTBOUND SHIPPING ONLY: Delivery from booth to carrier at close of show.

\$45.00 per 100# with a 200# minimum

UPS OUTBOUND SHIPPING SURCHARGE: Applies to return shipping of materials received at our warehouse or direct to showsite as well as outbound only shipments. ***This is in addition to material handling charges as detailed above.***

\$6.00 per piece (**\$18.00 minimum charge**) (no. pcs. x \$6.00)

SPECIAL HANDLING / STORAGE: Applies to loose / uncrated shipments or any shipments requiring return to our warehouse for shipping or customer pickup. Includes up to one week storage. These charges are in addition to any other services ordered.

\$30.00 per 100# with a 200# minimum

SHIPMENTS TO THE SHOW

Total This Page: _____

Shipped from (city) _____ Carrier _____ Pro no. _____

Shipping Date _____ Total number of pieces _____ Total weight of shipments _____

Show representative _____ Telephone _____

IMPORTANT: in order to trace shipments we must have the name of carrier and assigned bill of lading number - "PRO NO."

REFORWARDING INSTRUCTIONS

Ship to _____ (name) _____ (street address)

City, State, Zip _____ Prepaid Collect

Description _____ Number of pieces _____

Forward Via Motor Freight Air Freight UPS Fed Ex* Other _____

* **Fedex Ground Customers:** You must provide your own prepaid return labels for Fedex Ground due to their billing restrictions.

SPECIAL INSTRUCTIONS (Expedited shipping, Insurance, etc.):

PAYMENT POLICY / RECAP FORM
MUST ACCOMPANY THIS ORDER

EXHIBITOR _____ BOOTH# _____

ALL FREIGHT HANDLING CHARGES
MUST BE GUARANTEED WITH A
CREDIT CARD

ORDERED BY _____
(Please Print)